

## Sandpaper and Soft Eraser Rub Durability Fixture

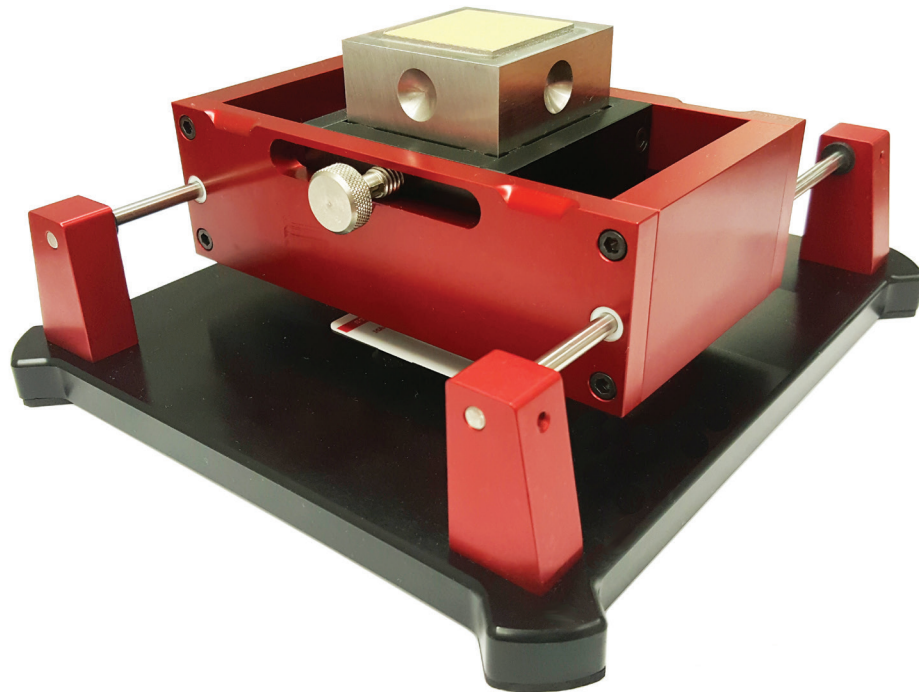

## Sandpaper and Soft Eraser Rub Durability Fixture

Q-Card's Sandpaper and Soft Eraser Rub Durability fixture is designed to determine the resistance of various card printing methods to abrasion caused by rough surfaces. The fixture holds a standard ID-1 size card in a cavity and uses a calibrated weight affixed with abrasive materials (sandpaper and soft eraser) to perform the tests. The calibrated weight affixed with the abrasives is held in a transport. The weight is then moved across the card surface by pushing and pulling the weight transport back and forth across the card surface.

The fixture is manufactured of a durable aircraft grade aluminum with a hard-anodized coating for durability. It has splayed feet and aggressive non-slip rubber feet for stability. The calibrated weight is made of stainless steel to provide years of rigorous testing and trouble-free service.

The fixture has two locking thumb screws: one is to position the abrasives over the card area to be tested; the second holds the calibrated weight up and out of the way when placing the new cards in the cavity to be tested.

The fixture is designed to perform the both the sandpaper and soft eraser rub test according to the following standards:

### **MasterCard CQM**

- Durability of Surface Printing—Sandpaper Rub
- Durability of Surface Printing—Soft Eraser

## Ordering Details

Part #	Description
906701	Sandpaper and Soft Eraser Rub Durability Fixture
906960	Sandpaper and Soft Eraser Consumables Kit

## Specifications

Weight - 9 lbs.

## Dimensions

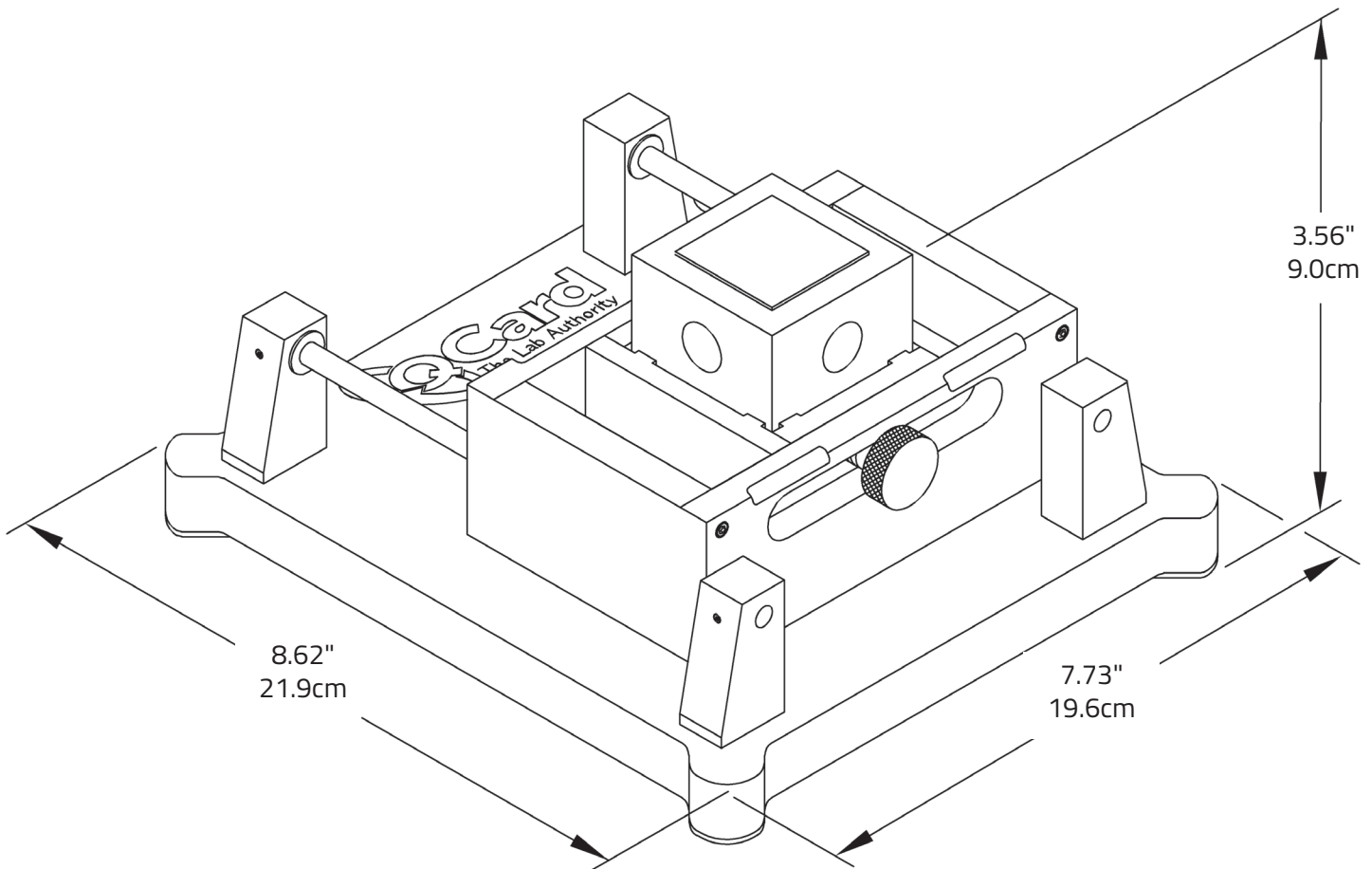

301 Reagan Street  
Sunbury PA 17801 USA  
Phone 570.286.7447  
Fax 570.286.2649  
[www.q-card.com](http://www.q-card.com)

Q-Card is an



**800-717-8007**